

ECC



UNIT IV
ISSUE 1

Creeds:
Defining Our
Beliefs

Church Times



Emperor Constantine Calls Church's Bishops to Council Meeting in Nicaea

CONSTANTINOPLE, 325 CE— Arguments in the Church have led the Emperor Constantine to call all the bishops for a Council meeting.

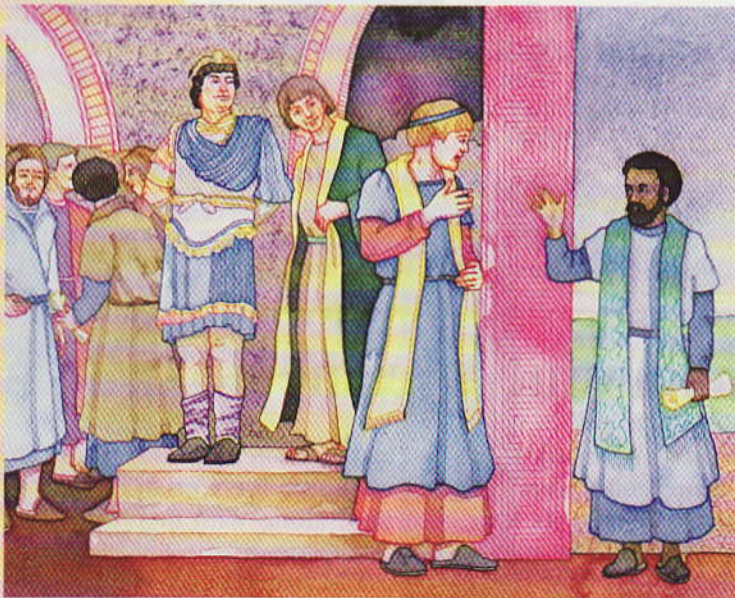

scars of their torture, imprisonment, or exile.

Eusebius of Caesarea, a historian, told us, "Those who have come here are the most distinguished ministers of God, from the many churches in Europe, Africa, and Asia.

"Constantine is the first ruler of all time to have gathered such a group in the bond of peace."

Bishops Set Standards

During the persecutions, many people were not able to hold on to their faith while being tortured. They gave in and rejected God.

The bishops have now set up a procedure that will allow these people to return to the Church if they ask to be admitted again.

The bishops have also established standards for the election and ordination of priests and bishops.

Debate Concerning Christ

A local debate about Jesus Christ as the Son of God began in Alexandria some time ago. It has led to serious conflict. Arius, a priest of that region, has been teaching that Christ, the Word, did not exist with God the Father from all eternity. His followers have been protesting in the streets—singing songs and shouting, "There was

About 300 bishops have traveled from their homes to Nicaea, not far from here. Their expenses are being paid by the Emperor, who has taken charge of this important Council himself. Some of the bishops are from the Greek-speaking East. Others are from the West, where Latin is the main language.

Because this gathering is happening so soon after the end of the persecutions of Christians, many who are here still bear the

when He was not! There was when He was not!"

In opposition to their view, Bishop Alexander condemned Arius and banned him from holding any office in the Church. Alexander believes that the Word (the Son) has existed from the very beginning of time. He has been assisted by a scholarly priest named Athanasius. Although he is not allowed to speak at the meeting, Athanasius has been working in the background to oppose Arius.

Disturbed by this conflict in Alexandria, the Emperor asked the Council to prepare a firm answer to the question, Who is Jesus Christ?

The matter was presented to the Council by Eusebius, Bishop of Nicomedia, who brought a written statement. The supporters of Arius told us they expected to persuade

the Council with logical arguments for their position.

Shouts of "Liar!," "Blasphemy!," and "Heresy!" were heard as the Council became outraged at the suggestion that Christ was only a creature. One member grabbed the statement from Bishop Eusebius' hand, ripped it to shreds, and trampled the pieces on the floor.

A Creed has now been written to state clearly that Christ is of the same "substance" as the Father. The Greek word for substance (*homoousia*) was suggested by the Emperor Constantine himself.

All bishops were asked to sign the new document now being called the Nicene Creed. Only a handful have refused, and they have been declared heretics by the Church and banished from their cities by the Emperor.

Early Christians Became Martyrs

From the early days of the Church, members of the Christian community were treated in a cruel way. Stephen was one of the first to die for his beliefs. He was stoned in Jerusalem for preaching about Jesus.

In many parts of the Roman Empire, Christians were blamed for evil deeds and were tortured and killed. Many were sent into the Circuses (Arenas) where they were chased by lions and other wild beasts. Others were beaten, burned, and stoned to death.

During the times of persecution, Christians were forbidden from worshipping

in public. Their books were seized and burned. Sacred places and objects were destroyed.

Because of the constant danger they faced, early Christians developed signals to identify one another. One such sign was the fish. The initial letters of the Greek word for fish (*ichthus*) stand for the words, "Jesus Christ, God's Son, Savior."

To use the sign, a Christian would draw half of a fish in the dirt. A non-Christian would think nothing of it. But other Christians would know what to do. They would complete the sign by drawing the other half of the fish.



How Constantine Became a Christian

The Roman Empire had many rulers. Some of the more famous ones were Julius Caesar and Augustus Caesar. At times, more than one man claimed to be emperor, and fighting broke out.

Constantine grew up hoping to become the ruler of the whole Roman Empire. He was patient and careful, and he waited until the time was right.

In 313, Constantine gathered his armies and marched on Rome. Maxentius, the ruler of Rome, led his army to meet Constantine on the Milvian Bridge.

The night before the battle, Constantine

had a dream he could not forget. He saw a vision of the Christian symbol, the *Chi Rho*, along with the words, "In this you shall conquer."

Chi and *Rho* are the first two letters of the Greek name, "Christ." Constantine had this symbol put on the shields of his soldiers. The battle was won, and Constantine issued the Edict of Milan. In this order, persecutions of Christians were stopped. Churches, cemeteries, and other properties were restored.

Constantine continued to support Christians and was baptized just before he died in 337.



Christian Worship Changes

In the early Church, Christians worshiped in small groups in private homes. Their services were simple. People gathered in secret, shared a meal, and celebrated the Eucharist.

Becoming a Christian was dangerous and required individuals to spend up to three years in preparation before being baptized.

After Constantine became emperor,

everything changed. People no longer had to hide their beliefs or be afraid of the authorities. Churches were built so that Christians could worship in public.

Many people wanted to become Christians right away, but they were not often willing to accept the conditions of baptism and repentance.

Celebrations of Epiphany, Easter, and Pentecost became festival occasions.

Answers:

1. Nicaea
2. Chi Rho
3. Martyr
4. Constantine
5. Alexander
6. Milan
7. Arius
8. Eusebius
9. Constantinople
10. Ichthus
11. persecution
12. Creed
13. blasphemy
14. heretic
15. homoousius

MEMORY CHALLENGE

File Edit Window Help

Open

Unit IV

- Church History
- Creeds: Defining Our Beliefs
- The Church's Worship Takes Form
- The Church's Reformation
- The Bible Is for All
- The Church Came to America
- Missionaries Are Sent Out
- The Church Acts in Society
- Christians Struggle For Unity
- We Celebrate Pentecost

Timeline (centuries)

4th 6th 14th 15th 16th 17th 18th 19th 20th

4th Century

4th Century-Key People and Events

✓ Athanasius, Nicene Creed, Ambrose

The Church Is Formed

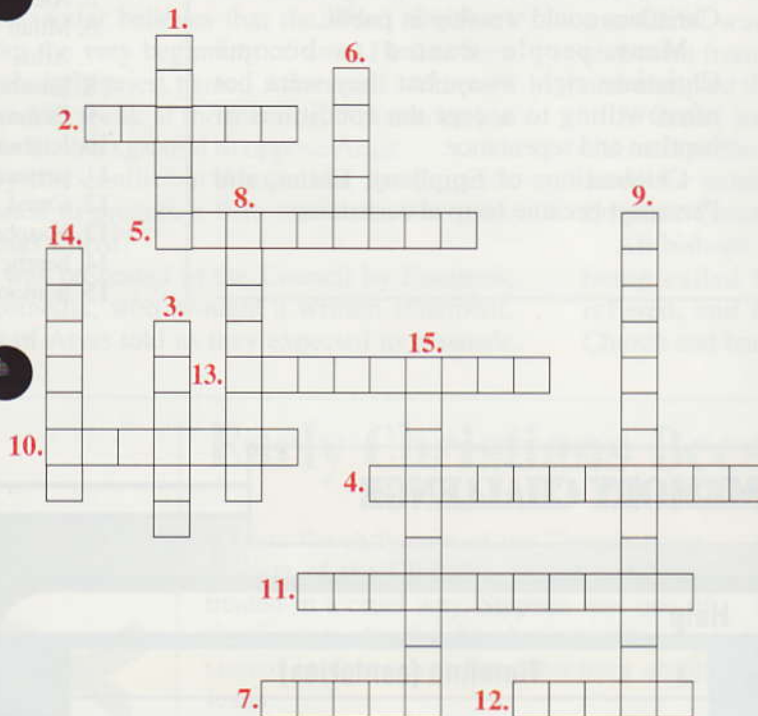

Clues:

1. Over 300 bishops gather here at the request of the Emperor.
2. A Christian symbol placed on the shields of Roman soldiers.
3. One who suffered and died for believing in Christ.
4. The emperor who ended the cruel treatment of Christians.
5. A bishop who believed that Jesus and God the Father existed from the beginning.
6. An edict declaring that a Christian's property would be restored.
7. A priest whose followers shouted his slogans in the streets.
8. The name of a historian from Caesarea who was present at the Council.
9. The Council was held not far from this city.
10. The Greek word for fish.
11. Cruel treatment of others, including torture and death.
12. A statement of belief.
13. A statement considered to be in contempt of God or to curse God.
14. One whose beliefs are in opposition to the established Christian faith.
15. A Greek word meaning "of one substance or being."

Unit IV: LEARNING SCRIPTURE

Verses for the Unit:

Session 1: *John 16:28; Philippians 2:11*

Session 2: *Romans 12:2; Romans 14:8*

Session 3: *Psalm 118:23; John 8:32; Romans 5:8*

Session 4: *Luke 24:32; II Timothy 3:15*

Session 5: *Matthew 5:16; John 17:18*

Session 6: *Luke 9:6; Romans 15:21*

Session 7: *Matthew 25:35; Galatians 3:28*

Session 8: *Romans 12:9; Ephesians 4:2*

Session 9: *Acts 1:5; I Corinthians 12:4-6*



LEARNING SCRIPTURE

Session 1

"I came from the Father and have come into the world; again, I am leaving the world and going to the Father." —*John 16:28* (NRSV)

". . . [A]nd every tongue should confess that Jesus Christ is Lord, to the glory of God the Father." —*Philippians 2:11* (NRSV)

ECC



**UNIT IV
ISSUE 2**

**The Church's
Worship
Takes Form**

Cross Year- Intermediate,
Episcopal Children's
Curriculum
Copyright ©1995
Virginia Theological
Seminary and Morehouse
Publishing

Church Times

Benedict Builds Monastery for Growing Number of Monks Joining Community

In the small community of Monte Cassino, a new structure has been built by the hands of men dedicated to God and led by a man named Benedict from Nursia.

This small village was chosen because it is far from any busy roads. It has been changed greatly by this new building called a monastery. The original spot was a place of pagan worship. The monks have torn down the altar that was there and built the new foundation right on top of it. They have now dedicated the place to God.

The brothers have taken vows of poverty, chastity, and obedience. They will establish a community where they will live under the Rule written by Benedict.

One of the monks told us about the requirements of the Rule. "They are very reasonable," he said. "Some places have much stricter rules, such as fasting for long periods of time and sleeping on the ground.

Benedict has given us a way to live that praises God in every part of our lives.

"We gather for prayer eight times a day. The services are called Matins, Lauds,

Prime, Terce, Sext, None, Vespers, and Compline.

"Benedict thinks we need to get proper rest and food to keep ourselves fit. We have two meals a day and sleep on beds with blankets and pillows.

"We also share in whatever work is necessary to maintain the monastery, where we live and work apart from the world. We spend part of our day studying the Scriptures and other writings in our library.

"The most important part of our Rule is our obedience to it and to Benedict, our abbot."

While this community is just for men, we have learned that one will be established nearby for women. This community will be called a convent, and it will be led by Benedict's sister, Scholastica.

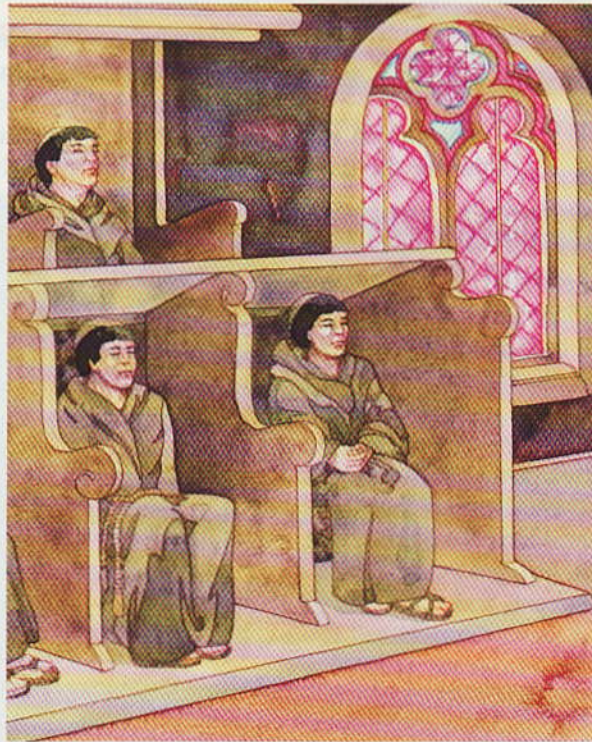

Anthony and His Pig Bring Warm Light

Anthony and his sister lived in a small village in Egypt. They were very young when their parents died and left them with a large amount of money and land.

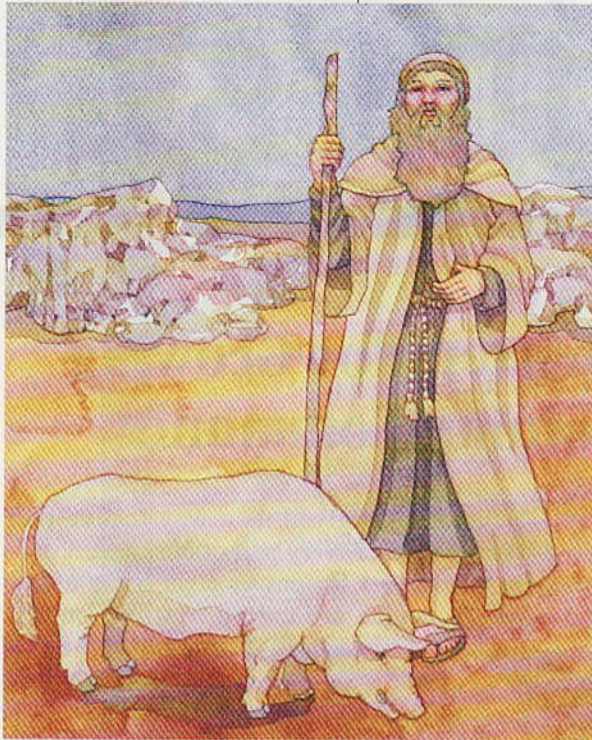

Anthony, the older, took good care of his sister and the property. Soon he was even richer. One day while in church he heard the Gospel story of the rich young ruler. Jesus' words were clear: "Go, sell your possessions, and give the money to the poor, and you will have treasure in heaven."

Anthony provided money for his sister. Then he sold everything that belonged to him, gave the money to the poor, and went into the desert to live.

People soon learned about what Anthony had done. They also saw him in the desert praying to God all during the days and nights. They knew he was a holy man. Others came to learn from him. He taught them discipline, prayer, and contemplation. Anthony was one of the first monks—people who left behind everything they had in order to give all their attention to worshipping God.

A Legend of Anthony

People soon began to tell stories about Anthony and to call him a saint and a miracle worker. One legend from Italy tells the following story.

Anthony sold all his

possessions except for one pig. Often, he was seen in the desert praying to God with his staff in his hand and his pig by his side.

The desert was a very hot place in the day when the sun beat down upon the sand, but the nights were very cold and dark. The people who lived there had no way to keep warm. They wished they could keep a piece of the sun and hold on to it from evening until the next morning.

The people thought, "A saint could help us. We can ask Anthony, the holy man, to help us keep a piece of the sun for the nighttime. Anthony wanted very much to help the people. He knew how much they suffered in the cold.

Anthony thought and prayed for a long time. Finally, he knew what to do. He took his staff and his pig and began the long journey to the deep center of the earth. There in the burning fires of hell lived the devil and his workers.

Anthony knocked at the big iron gates. The devil's helpers would not let him in because they knew he belonged to God. Anthony kept knocking until the devil came to the gate.

"We don't want you in here. We only want those who lie, and cheat, and kill or act like pigs."

Anthony replied, "It is cold out here. If you will not let me in, at least let my pig in to warm himself by the fire." The devil agreed. But when the pig got inside, he went crazy—running around and knocking things every which way. The more the devil and the others tried to catch him, the more damage the pig caused.

"Get in here, and stop this pig!" shouted the devil. They let Anthony in, and the pig came and stood quietly by his side. Anthony then sat down by the fire. He stuck the end of his staff in the flame.

"You can't stay here!" the devil yelled, so Anthony got up to leave. When he took his staff out of the fire, the end was burning. The devil saw it and blew it out. "I'm not letting you take that fire out of here."

But Anthony just smiled. When he got outside the gates, he blew on the end of the staff. At once, it glowed brightly. Anthony took the fire back to the people and gave them warmth and light in the darkness.

Monasticism Yesterday and Today

Anthony lived in the desert. Benedict and others lived in monasteries or convents. Many men and women dedicated their lives in this way. Those who follow St. Benedict are called Benedictines.

Other groups gathered under different leaders and had different rules. One of these was Francis of Assisi who established the order now known as the Franciscans. Two others are the Dominicans and the Jesuits.

For a long time, monasticism was not a part of the Church of England. It was considered too Roman for those who chose to follow a Protestant way. Today, however, there are thirty-two such orders in the Episcopal Church. Some live in monasteries and convents. Others are people you may meet in church or on the street.

Hilda Dedicated Her Life to God

Hilda was a famous woman who lived in the seventh century in northern England. She was an abbess, the leader of a monastery that had both men and women living in community.

Hilda was born into a family of kings. Her great uncle was King Edwin, and her sister's son became king of East Anglia.

Hilda lived for thirty-three years as a noble Christian woman. Then she decided to dedicate the rest of her life to God. The bishop asked her to establish a monastery not far from her home.

Hilda established a rule that provided for everyone to share all things. She taught righteousness, mercy, purity, and especially

peace and justice. She was a very wise woman, and many people—ordinary folk and kings and princes—asked her for advice.

A great meeting, called the Synod of Whitby, was held under Hilda's guidance. The purpose was to decide on the date for Easter. Some churches followed the Eastern calendar and others the Western. This caused Easter to be celebrated at different times during the same year. Many people were confused by this.

The Synod of Whitby chose the Western (Roman) date for celebrating the resurrection of Christ.



Puzzle Answers

1. Abbess
2. Monastery
3. Monk
4. Nuns, Convent
5. Benedict
6. Obedience, Abbot
7. Poverty, Chastity

MEMORY CHALLENGE

The Monastic Life

Use the words listed on the right, and put them in the blanks of the sentences.

1. Hilda was in charge of a monastery, and her title was _____.
2. Men who have dedicated their lives wholly to God live in a place called a _____.
3. Anthony lived apart from the world and served God. He was one of the first to be called a _____.
4. Women who devoted themselves to God were called _____, and lived in a _____.
5. Physical work, along with proper food and rest, are included in the Rule of St. _____.
6. Men who took a vow of _____ in the community of St. Benedict had to obey the Rule and the _____.
7. Two other important vows of monasticism are _____ (giving up money and possessions), and _____ (keeping your body clean and pure.)

MONASTERY
CONVENT
ABBOT
ABBESS
BENEDICT
MONK
NUNS
POVERTY
CHASTITY
OBEDIENCE

Unit IV: LEARNING SCRIPTURE

Verses for the Unit:

Session 1: *John 16:28; Philippians 2:11*

Session 2: *Romans 12:2; Romans 14:8*

Session 3: *Psalms 118:23; John 8:32;*

Romans 5:8

Session 4: *Luke 24:32; II Timothy 3:15*

Session 5: *Matthew 5:16; John 17:18*

Session 6: *Luke 9:6; Romans 15:21*

Session 7: *Matthew 25:35; Galatians 3:28*

Session 8: *Romans 12:9; Ephesians 4:2*

Session 9: *Acts 1:5; I Corinthians 12:4-6*



LEARNING SCRIPTURE

Session 2

“Do not be conformed to this world, but be transformed by the renewing of your minds, so you may discern what is the will of God—what is good and acceptable and perfect.” —*Romans 12:2 (NRSV)*

“If we live, we live to the Lord, and if we die, we die to the Lord; so then if we live or die, we are the Lord’s.” —*Romans 14: 8 (NRSV)*

ECC



**UNIT IV
ISSUE 3**

**The Church's
Reformation**

Church Times

German Monk Challenges the Selling Of Indulgences by the Pope's Agent

WITTENBURG, GERMANY, Late November, 1517—On October 31, the eve of All Saints, a monk named Martin

Luther posted 95 theses on the wooden doors of the Castle Church in this city.

Luther has become a noted professor of Scripture at the University of Wittenberg. He seems surprised by the responses to his statements.

The most violent reaction has come from a Dominican named John Tetzel who has been selling indulgences in the town square for some time. Tetzel has called Luther a heretic. He boasted, "I will take this case to the Pope."

Luther, a quiet man who enjoys debating and talking with the other teachers at the University, says he wrote the 95 theses to continue a previous debate.

He admits he is opposed to the abuse of indulgences. He especially dislikes Tetzel's repeated rhyme, "Once the coin into the coffer clings, a soul from purgatory heavenward springs!"

An assistant to Tetzel told us, "Brother John is simply continuing a longstanding practice of the Church. We have always sold indulgences—official papers declaring unfortunate souls to be forgiven of their sins. If an indulgence is purchased for a loved one already dead, that person's soul will be freed from the tortures of hell.

"What right has this monk Luther to tell us we are wrong? He is a heretic, a radical, who should be excommunicated."

A spokesman for Luther told us, "Martin says if it is true that the pope can free souls from torture in purgatory, then he ought to use that power out of love and not for money.

"In fact, the pope should sell all he has—even St. Peter's in Rome—and give the money to the poor."

Many of Luther's friends in Wittenberg fear for his safety. The 95 theses, originally written in Latin, are being translated into German. Copies have spread throughout the country.

Pope Leo of Rome and Emperor Maximilian have expressed outrage at Luther's actions and demand that he be silenced.



Cross Year—Intermediate,
Episcopal Children's
Curriculum
Copyright ©1995
Virginia Theological
Seminary and Morehouse
Publishing

Reformation Spreads Through Europe

Luther's posting of 95 theses on October 31, 1517, is said to be the beginning of the Protestant movement that sought to purify the Church.

Many others joined Martin Luther in declaring the practices of the Church of Rome corrupt and seeking to establish their own forms of Christianity.

In Germany, those who followed the teachings of Martin Luther were known as Lutherans. In Geneva, Switzerland, John Calvin's ministry resulted in the spread of Reformed churches. Others followed, establishing their own statements of beliefs and practices.

England Breaks With Rome

In England, the Reformation took a different turn. At first, King Henry VIII spoke out against the Protestants and received the title "defender of the faith."

However, Henry had personal interests to pursue. He was determined to secure a son to follow him as king. He and his wife, Catherine of Aragon, had a daughter, Mary Tudor. When Catherine could have no more children, Henry wished to divorce her.

The king asked the pope to annul the marriage (declare that it had never taken place). He wanted to be free to marry Anne Boleyn. When the pope refused, Henry declared himself head of the Church of England. He married Anne, who bore him a second daughter who was named Elizabeth.

The king later married Jane Seymour, and they had a son who became Edward VI following Henry's death.

After his disagreement with Rome, Henry began to be influenced by those in England who wanted the Protestant movement to spread to England.

Thomas Cranmer, Archbishop of Canterbury, supported the king and hoped that his actions would lead to further changes. Cranmer ordered that the Bible be translated into English and placed in every church. In 1549, Cranmer prepared the first edition of *The Book of Common Prayer* for use in worship. It gave the English a liturgy in their own language.

Two Queens, Two Religions

After the death of Henry VIII, his son Edward VI came to the throne. Edward was a strong supporter of the Protestants, and many reforms were carried out. Once again, the people were given the cup as well as the bread at Holy Communion. Clergy were granted permission to marry.

King Edward's health was poor, and he died after ruling only six years. His half-sister, Mary Tudor, became queen. She is known as "Bloody Mary."

Raised a Catholic, Mary resented her

father's rejection of the Catholic faith. She raged throughout the kingdom, killing many who had declared themselves Protestant reformers. Many bishops, including Thomas Cranmer and his close associates Hugh Latimer and Nicholas Ridley, were burned at the stake.

After only five years as queen, Mary Tudor died. She was succeeded by her half-sister Elizabeth I. When Elizabeth heard of her sister's death, she said, "This is the Lord's doing, and it is marvelous in our eyes."

Continued on page 3



Thomas Cranmer

Luther's posting of 95 theses on October 31, 1517, is said to be the beginning of the Protestant movement that sought to purify the Church.

TWO QUEENS,
Continued from page 2

Elizabeth believed that her father had done the right thing in supporting the Reformation. She set about to restore Protestantism in England. Elizabeth ordered a new version of *The Book of Common Prayer* that included the text: "The body of our Lord Jesus Christ, which was given for thee, preserve thy body and soul unto everlasting life. Take and eat this in remembrance that Christ died for thee, and feed on him in thy heart by faith, with thanksgiving."

Elizabeth I reigned as Queen of England from 1548-1603.



Puzzle Answer:
This is the Lord's doing, and it is marvelous in our eyes.

MEMORY CHALLENGE

File Edit Window Help

Open

Unit IV

- Church History
- Creeks: Defining Our Beliefs
- The Church's Worship Takes Form
- The Church's Reformation
- The Bible Is for All
- The Church Came to America
- Missionaries Are Sent Out
- The Church Acts in Society
- Christians Struggle For Unity
- We Celebrate Pentecost

Timeline (centuries)

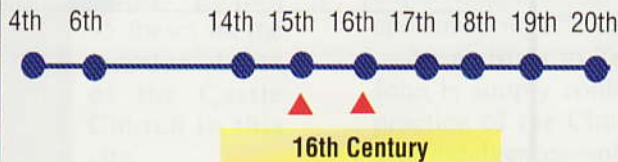

16th Century Key People and Events

- ✓ Martin Luther, John Calvin, Protestant Reformation
- ✓ Thomas Cranmer, first edition of *The Book of Common Prayer*



Directions: The letters in each vertical column go into the squares directly below them, but not necessarily in the same order. A blue square means the end of a word. When you have put all letters in their correct squares, you will discover a message.

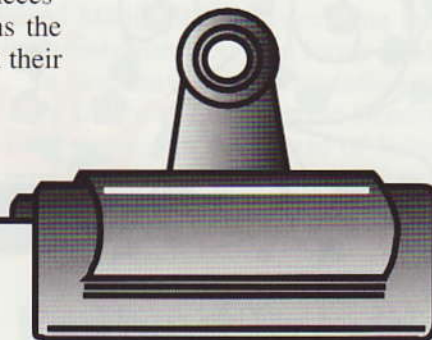

A Queen's Psalm

M D O I E L I A S D I I T O O S D E Y E S
 A R I N G O U N T H E L U R ' S
 T H V S S N I R



Unit IV: LEARNING SCRIPTURE

Verses for the Unit:

Session 1: *John 16:28; Philippians 2:11*

Session 2: *Romans 12:2; Romans 14:8*

Session 3: *Psalm 118:23; John 8:32; Romans 5:8*

Session 4: *Luke 24:32; II Timothy 3:15*

Session 5: *Matthew 5:16; John 17:18*

Session 6: *Luke 9:6; Romans 15:21*

Session 7: *Matthew 25:35; Galatians 3:28*

Session 8: *Romans 12:9; Ephesians 4:2*

Session 9: *Acts 1:5; I Corinthians 12:4-6*



LEARNING SCRIPTURE

Session 3

"This is the Lord's doing, it is marvelous in our eyes."

—*Psalm 118:23 (NRSV)*

"... [A]nd you will know the truth, and the truth will make you free."

—*John 8:32 (NRSV)*

"But God proves his love for us in that while we still were sinners Christ died for us." —*Romans 5:8 (NRSV)*

ECC



UNIT IV
ISSUE 4

The Bible Is
for All

Cross Year- Intermediate,
Episcopal Children's
Curriculum
Copyright ©1995
Virginia Theological
Seminary and Morehouse
Publishing

Church Times

Tyndale's Bible Translation Is Burned Soon After It Is Smuggled into England

ANTWERP, BELGIUM, 1534—A young scholar from Oxford, William Tyndale, has almost completed an English translation of the Bible while living in this city. We interviewed him just as copies of his work were being printed for transport to England.

"I studied Greek and Hebrew at Magdalen College at Oxford. It was there that I came to believe that the Bible belonged in the hands of the people.

"I have said many times that if God spared my life, I would see that the boy who works in the fields will know more Scripture than the scholars at Oxford.

"I first went to the bishop of London, seeking his support for an English Bible. I soon realized that not only was there no room in the bishop's palace to translate the New Testament, but there was no place to do it in all of England.

"In 1524, I left for Germany. I have lived in Hamburg, Cologne, and Worms. There I was able to complete the New

Testament and see it printed. We made 6,000 copies and got them into England.

"In London, the bishops preached against it and seized all the copies they could get their hands on, burning them in front of the great Cathedral of St. Paul. It was a very dark day for us when we heard about it.

"I am now living with English merchants who have been very good to me. I hope to complete the Old Testament soon. I have been working from the original Hebrew and Greek as there are many errors in the Latin Vulgate.

"Word has reached us that Anne Boleyn has shown a copy of my translation to King Henry. This gives me great hope that I may someday return to my beloved England."

Tyndale has been living with Thomas Poyntz and his wife in their home here. We are grateful for the opportunity to interview Mr. Tyndale, for we understand that his life has been threatened on many different occasions.

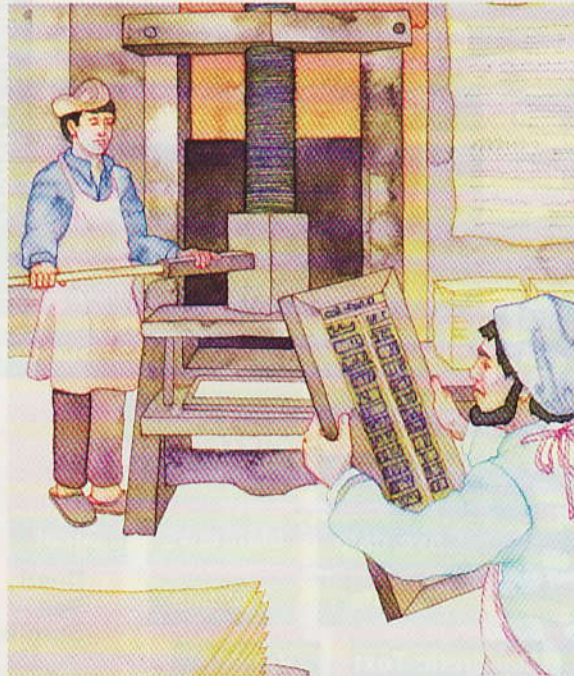

Gutenberg Invents the Printing Press

In Mainz, Germany, a printer named Johannes Gutenberg designed and built the first commercially effective printing press.

This invention changed forever the way books are produced. No longer do scribes have to spend long hours copying manuscripts by hand. A single book could take months to complete.

Gutenberg, whose father was a scribe, appreciated the difficult work and was determined to make it easier. He experimented with many different methods.

Beginning with steel, he cut each letter

of the alphabet, both upper and lower case, many times. These were then used to make a mold.

Finally, Gutenberg was ready to print a book. He chose the Bible. In 1452, Gutenberg produced the first printed Bible, a copy of the Latin Vulgate. Twenty copies of the Gutenberg Bible still exist, and twelve of these are in the United States.

The process introduced by Gutenberg was the basic form of printing until the dawn of our own age of photo-processing and computers.

How Bible Translators Do Their Work

Translating the Bible into languages people can read and understand is not easy. First, the translators must be able to read and understand the languages in which the Bible was originally written.

The Hebrew Scriptures (Old Testament) were written in Hebrew, a language that has no vowels (a, e, i, o, and u). Small markings called "vowel points" were added later.

The New Testament was originally written in Greek, a language with no punctuation (periods, commas, etc.).

After translators learn the original languages, they need to be able to understand what the words meant for the people who used them in Bible times. Then they must decide what the words are likely to mean to people of our own time.

The next task is to choose words in the language of today that will express accurately what the writers intended. Direct translation, word for word, may make no sense to today's reader. So the translators need to think about words that have the best chance of being understood.

Many Translations

The original manuscripts of the Scripture were written between 1500 BCE and 100 CE. In about the year 400, the Bible was translated into Latin by a monk named Jerome. This translation is known as the Vulgate, which means "common." Latin was the common language of the Roman empire.

John Wycliffe began a handwritten English translation in 1380, but it was banned and destroyed.

Continued on page 3

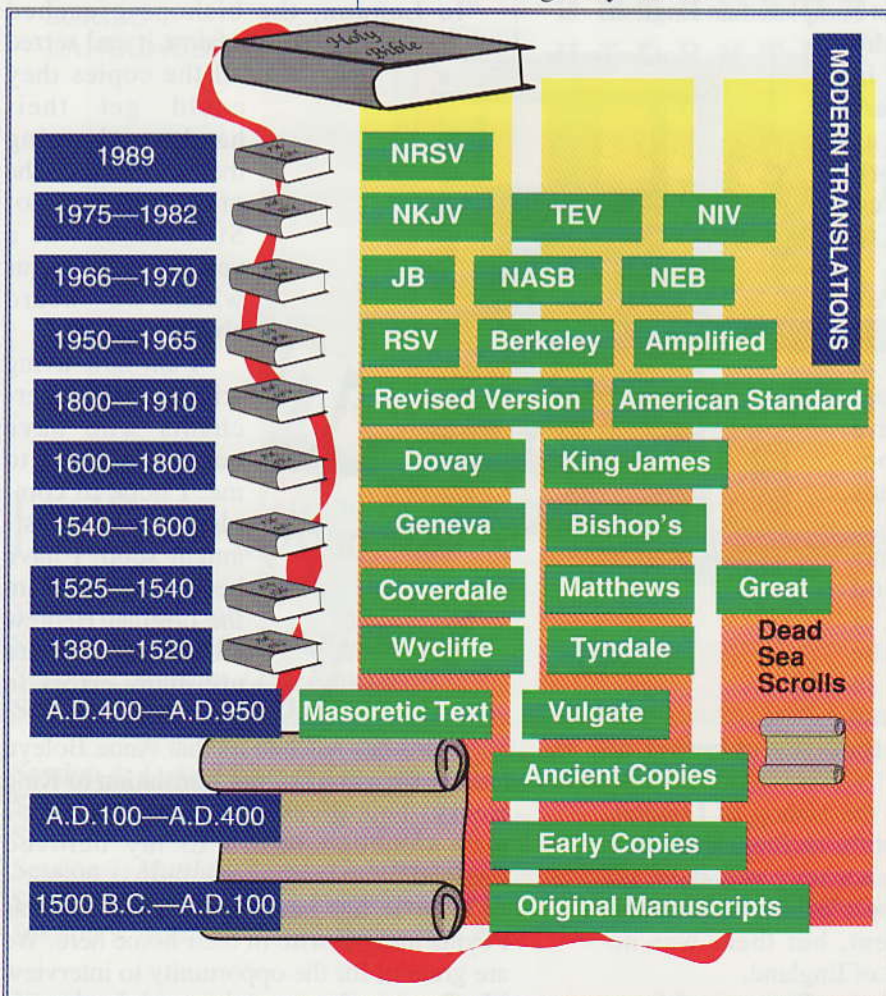

BIBLE, Continued from page 2

William Tyndale was able to succeed because of his knowledge of Hebrew, Greek, and Latin, and because of the invention of the printing press.

Tyndale's translation was extremely accurate for the conditions under which he worked. About nine-tenths of his translation was used in the King James Version of 1611. Tyndale was executed before he finished the Old Testament.

The King James Bible, authorized by King James of England, was the most widely-used English translation until the middle of the twentieth century. Over the

last several decades, scholars have worked to revise the language, making the Bible more understandable for modern readers.

In 1952, the Revised Standard Version (RSV) was completed. In 1989, the New Revised Standard Version (NRSV) was published. Its language is more inclusive, with fewer uses of "men" and "brother." The text now refers instead to "people" and "brothers and sisters."

Many other translations of the Bible have appeared in print. More than 5,000 languages are spoken by the world's people, and the Bible is available in almost 2,000 of these. Would you like to help translate the Bible into one of the remaining 3,000 tongues?

Puzzle Answer:

SNSOALRSAHSILGNEEKRE
 MJONCDTRANSLATIONAHA
 AROMOEREVISEDHAHSYTTY
 CAOTOHEGRDIPNHEBREW
 MELSIERAIIRCANGITCWT
 EADSRCTUEORIPNTRATSN
 WNTMOOSGMFPNAAAYSEAME
 AVEEBHRNWXNTAISNLEYM
 ENSCAELAOOEILEMEDRKA
 NOTABIBLEMANTANDEANT
 SIAGREBNETUGRSIDALLS
 CYMOYSNSNMEPRATGTETE
 LFEWTPCWETIRETAHUYNT
 TRNSIDLRRAAEYLLRYGIW
 EETNNRUEIASSMEORLHAE
 HIDHMTBLBBIISLPRALRIN
 YRIHPTIOSBEAEZNIIGLNE
 ACGIOCBOAIRNNDAGBYUS
 LERRELKINGJAMESUSAOT
 CCICRHCRLIMSEPTOINNA
 STANDARDNEITRHOBNEFM

MEMORY CHALLENGE

Word Search—Holy Scripture

Directions: Find the words below.
The words may be across, up and down,
diagonal, or backwards.



TYNDALE
BIBLE
ENGLISH
ENGLAND
NEW TESTAMENT
LATIN
TRANSLATION
GUTENBERG
REVISED
HEBREW
OLD TESTAMENT
GREEK
PRINTING PRESS
KING JAMES
STANDARD
EUROPE
SCRIPTURE
OXFORD
SCRIBE
LANGUAGE

S	N	S	O	A	L	R	S	A	H	S	I	L	G	N	E	E	K	R	E
M	J	O	N	C	D	T	R	A	N	S	L	A	T	I	O	N	A	H	A
A	R	O	M	O	E	R	E	V	I	S	E	D	A	H	S	Y	T	T	Y
C	A	O	T	O	H	E	G	R	D	I	P	N	H	E	B	R	E	W	E
M	E	L	S	I	E	R	A	I	R	C	R	A	N	G	I	T	C	W	T
E	A	D	S	R	C	T	U	E	O	R	I	P	T	N	R	A	T	S	N
W	N	T	M	O	O	S	G	M	F	P	N	A	A	Y	S	E	A	M	E
A	V	E	E	B	H	R	N	W	X	N	T	A	I	S	N	L	E	Y	M
E	N	S	C	A	E	L	A	O	O	E	I	L	E	M	E	D	R	K	A
N	O	T	A	B	I	B	L	E	M	A	N	T	A	N	D	E	A	N	T
S	I	A	G	R	E	B	N	E	T	U	G	R	S	I	D	A	L	L	S
C	Y	M	O	Y	S	N	S	N	M	E	P	R	A	T	G	T	E	T	E
L	F	E	W	T	P	C	W	E	T	I	R	E	T	A	H	U	Y	N	T
T	R	N	S	I	D	L	R	R	A	A	E	Y	L	L	R	Y	G	I	W
E	E	T	N	N	R	U	E	I	A	S	S	M	E	O	R	L	H	A	E
H	I	D	H	M	T	B	L	B	B	I	S	L	P	R	A	L	R	I	N
Y	R	I	H	P	T	I	O	S	B	E	A	E	Z	N	I	G	L	N	E
A	C	G	I	O	C	B	O	A	I	R	N	N	D	A	G	B	Y	U	S
L	E	R	R	E	L	K	I	N	G	J	A	M	E	S	U	S	A	O	T
C	C	I	C	R	H	C	R	L	I	M	S	E	P	T	O	I	N	N	A
S	T	A	N	D	A	R	D	N	E	I	T	R	H	O	B	N	E	F	M

Unit IV: LEARNING SCRIPTURE

Verses for the Unit:

Session 1: *John 16:28; Philippians 2:11*

Session 2: *Romans 12:2; Romans 14:8*

Session 3: *Psalms 118:23; John 8:32;*
Romans 5:8

Session 4: *Luke 24:32; II Timothy 3:15*

Session 5: *Matthew 5:16; John 17:18*

Session 6: *Luke 9:6; Romans 15:21*

Session 7: *Matthew 25:35; Galatians 3:28*

Session 8: *Romans 12:9; Ephesians 4:2*

Session 9: *Acts 1:5; I Corinthians 12:4-6*



LEARNING SCRIPTURE

Session 4

“They said to each other, ‘Were not our hearts burning within us while he was talking to us on the road, while he was opening the scriptures to us?’” —*Luke 24:32 (NRSV)*

“... [A]nd how from childhood you have known the sacred writings that are able to instruct you for salvation through faith in Christ Jesus.”
—*II Timothy 3:15 (NRSV)*

ECC



**UNIT IV
ISSUE 5**

**The Church
Came to
America**

Church Times



Service of Holy Communion Celebrated At Jamestown in the Colony of Virginia

LONDON, September, 1608—We have received word from the colonies that the three ships sent out by the London Company have arrived in the New World.

In all, 144 settlers sailed in December and arrived on May 13, 1607. The following is from a letter written by Robert Hunt, minister of the Church of England, who accompanied the group:

“When we set out in bleak December, I prayed for our safety and sal-

vation. I now offer God many prayers of thanksgiving for our safe deliverance to these shores.

“After many difficult months at sea, when our dependence on God for our very lives became more real each day, we finally arrived in this gracious land.

“Our very first task, upon setting foot on dry land, was to kneel and give our heartfelt thanks to our Lord God for safe deliverance.

“As soon as possible we prepared a crude altar by bringing planks from the ship and placing them across two piles of

rocks. An altar rail was formed by tying a slender pine between two trees.

“The crew rigged a sail over the Communion Table to protect it and me from the rain. But the weather proved fair with blue skies above as we gathered to celebrate Our Lord’s Supper in this new land for the first time.

Colony Has New Chapel

“Many days have passed since that day, when we gave thanks to God for our safe journey and for the many gifts of this land. I have come to love this place that we call Jamestown after our beloved king.

“The land is fair with rivers filled with fish and crabs. The game is abundant in the nearby forests. Rabbit, squirrel, fox, beaver, and timber wolf have been seen. The wild flowers that seem to spring up under our feet are beautiful shades of blue, violet, and pink.

“Since we have arrived, our small village, so far from my beloved Oxford, has been secured and we have built a chapel. The chapel is sixty feet long by twenty-four feet wide. It is very light within as we worship our Lord.

“Each day we celebrate morning and evening prayer. On Sundays we hold services with sermons two times. I am grateful that we are able to forgive one another as we come together for worship.

“It is my hope that we will fulfill our goals to establish a permanent settlement in this new land that is dedicated to the English Church and to the Crown.”

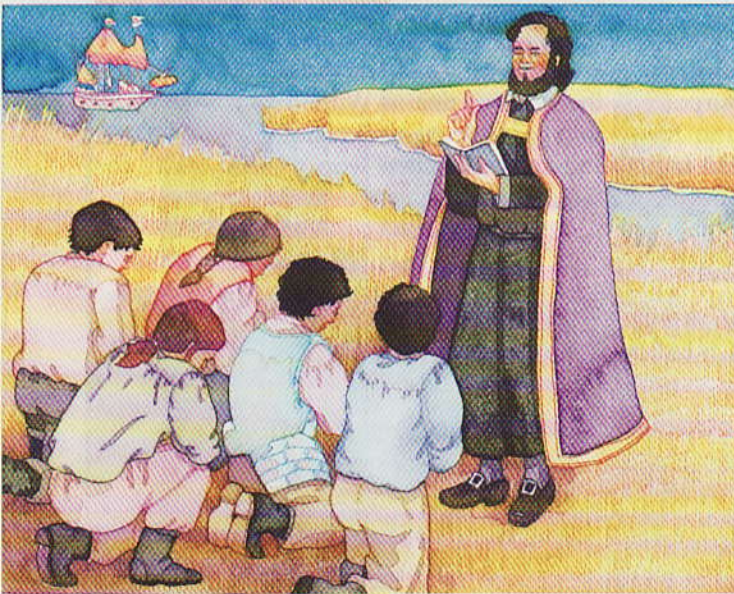

Cross Year—Intermediate,
Episcopal Children’s
Curriculum
Copyright ©1995
Virginia Theological
Seminary and Morehouse
Publishing

Church of England Establishes College At Williamsburg, North of Jamestown

The initial purpose of the school is to provide education for the children of colonists and for the building and maintaining of a school for Christianizing the Native American Indian.

WILLIAMSBURG, Virginia, Christmas, 1700—Today the President and founder of the Royal College of William and Mary, the Rev. James Blair—along with the Latin Master, the Writing Master, and a number of boarding students—moved into the first completed building.

After many years of planning and waiting, the college has now finished the Wren Building, which is named for its famous architect, Sir Christopher Wren.

In April, 1661, Mr. Blair presented a petition to the Virginia Assembly to ask that a college be established in the colony. Two earlier attempts to provide for the education of the colonial residents failed because of lack of support by the Crown.

Mr. Blair's petition was heartily endorsed by the Assembly and supported by colonists who pledged financial assistance. Mr. Blair then took his petition to England and won the support of Queen Mary and her husband, King William.

Mr. Blair returned to Jamestown with the Charter to establish the Royal College of William and Mary. The initial purpose of the school is to provide education for the children of colonists and to build and maintain a school for Christianizing the

Native American Indian.

It is hoped that these Indian youth will enter the ordained ministry of the Church of England.

The first step toward developing the college was to set up a grammar school. The location was several miles north of Jamestown, in the area of Bruton Parish. The town surrounding the school is named Williamsburg in honor of the King.

First College Is in Massachusetts

The College of William and Mary is the second such place of learning to be established in the new world. Harvard College, in Cambridge, Massachusetts, was established by an act of the general court of the Massachusetts Bay Colony in 1636.

At that time the court set aside 400 pounds to start the school. In 1638, John Harvard left a portion of his estate, 780 pounds, and 260 books to the college. Following this bequest, the College was named in Mr. Harvard's memory.

The purpose of Harvard College is much the same as that of William and Mary. It is to provide for the education of English and Indian young men who wish to study for the ministry.

First American Bishop Consecrated

On November 14, 1784, Samuel Seabury was consecrated bishop by three bishops in Scotland. This action was considered necessary by the Church of England representatives in Connecticut, in order to provide leadership for the churches in the colonies.

Since the beginning of the Revolutionary War, the clergy of the Church of England have been in difficulty. Since they were paid by the Crown, they had to remain loyal to the King or lose their income and their parishes.

Many who chose to remain loyal returned to England after the colonial victory at Yorktown. Others became American patriots and yet

wished to remain a part of the Church of England.

Since this was not completely possible, efforts were made to establish the Church in America. In 1783, the Protestant Episcopal Church in America was formed.

It is essential in the newly-organized Church to have bishops so that new clergy can be ordained. Thus, Samuel Seabury has made this historic trip and achieved the goal of being the first person ordained a Bishop of the Episcopal Church.

It is hoped that two other bishops will be consecrated soon. Three bishops are needed to ordain new bishops in this country. The Rev. William White of Philadelphia, former chaplain to the Continental Congress, is said to be one of the next candidates.

Settlement in New World Is Perilous

The establishment of the English colonies in the New World was not an easy one. There were many dangers—difficult ocean voyages, wild animals, Indians, and lack of food—that caused many to die.

Robert Hunt, the first Anglican to celebrate Eucharist in the New World, died less than two years after his arrival.

Before 1660, sixty-seven clergy were sent to the colonies by the Virginia Com-

pany (formerly the London Company). Within five years, forty-four of them had died.

Still, the English settlers were determined to establish themselves and the presence of the Church of England in the colonies.

While other religious groups began to establish themselves in the New World, the Church of England remained strong and dominant.

Answers:

1. EUCHARIST
2. PROTESTANT
3. WILLIAM WHITE
4. SEABURY
5. CONSECRATED
6. EPISCOPAL
7. JAMESTOWN
8. NATIVE AMERICANS
9. ROBERT HUNT
10. WILLIAM AND MARY
11. WILLIAMSBURG
12. ARCHBISHOP
13. ANGLICAN

HOLY COMMUNION

MEMORY CHALLENGE

File Edit Window Help

Open

Unit IV

- Church History
- Creeds: Defining Our Beliefs
- The Church's Worship Takes Form
- The Church's Reformation
- The Bible Is for All
- The Church Came to America
- Missionaries Are Sent Out
- The Church Acts in Society
- Christians Struggle For Unity
- We Celebrate Pentecost

Timeline (centuries)

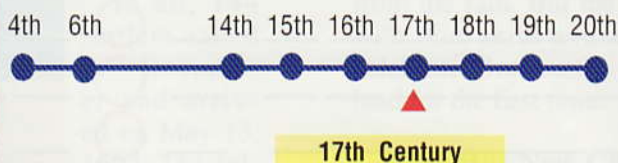

17th Century-Key People and Events

✓ Virginia and Massachusetts Bay colonies



Church in the New World

Fill in the puzzle below to discover a name for the celebration of the Lord's Supper. The letters for the name are in the circles.

Clues:

1. A word for the Great Thanksgiving.
2. One who claims differences with traditional Roman Catholic faith and practice.
3. First Episcopal bishop of Philadelphia.
4. First bishop of the Episcopal Church in America: Samuel _____.
5. To be made a bishop.
6. New name of the Anglican Church in America.
7. First permanent colony in Virginia.
8. People who first lived in the New World.
9. First Anglican to celebrate Holy Communion in the New World.
10. A college in Williamsburg, Virginia.
11. A town named for the King of England.
12. Head of the Church of England is the _____ of Canterbury.
13. A person who is a member of the Church of England and its provinces.

1.	_____	○	_____
2.	_____	○	_____
3.	_____	○	_____
4.	_____	○	_____
5.	_____	○	_____
6.	_____	○	_____
7.	_____	○	_____
8.	_____	○	_____
9.	_____	○	_____
10.	_____	○	_____
11.	_____	○	_____
12.	_____	○	_____
13.	_____	○	_____

Unit IV: LEARNING SCRIPTURE

Verses for the Unit:

- Session 1: *John 16:28; Philippians 2:11*
- Session 2: *Romans 12:2; Romans 14:8*
- Session 3: *Psalms 118:23; John 8:32; Romans 5:8*
- Session 4: *Luke 24:32; II Timothy 3:15*
- Session 5: *Matthew 5:16; John 17:18***
- Session 6: *Luke 9:6; Romans 15:21*
- Session 7: *Matthew 25:35; Galatians 3:28*
- Session 8: *Romans 12:9; Ephesians 4:2*
- Session 9: *Acts 1:5; I Corinthians 12:4-6*



LEARNING SCRIPTURE

Session 5

“In the same way, let your light shine before others, so that they may see your good works and give glory to your Father in heaven.”

—*Matthew 5:16 (NRSV)*

“As you have sent me into the world, so I have sent them into the world.” —*John 17:18 (NRSV)*

ECC



**UNIT IV
ISSUE 6**

**Missionaries
Are Sent Out**

Church Times

Paul Mazakute, Full-Blooded Dakota, Ordained Priest by Nebraska Bishop

Among the Sioux, 1869—As a result of many years of work by Episcopal missionaries to the Sioux* people, a dream has come true for Paul Mazakute. He has been ordained a priest in his beloved church. The Bishop of Nebraska was the Celebrant.

In 1863, the Sioux were forced to march westward from Minnesota to Crow Creek. It was a very difficult trek, and many died from poor conditions and lack of medical care.

Traveling with the Sioux was a young man from Connecticut, Samuel D. Hinman. Samuel is a graduate of Seabury Divinity School, and he has spent years among the Sioux.

When the Sioux were forced to move again in 1866, Father Hinman moved with them. This time they traveled overland to the new Santee Reservation. But the farmers whose land had been taken for the reservation were hostile to this hardy band of destitute people.

With very little reserves, Father Hinman was able to build a chapel at Bazille. Here he ministered to his flock

with no financial help from the Church Mission Board. He depended on gifts from supporters in the eastern States.

One of Father Hinman's significant accomplishments is a translation of *The Book of Common Prayer* into the Santee language, in 1864. The Prayer Book is used to teach the people to read as well as pray. They have come to love it deeply.

Tragedy struck when the chapel at Bazille Creek was destroyed by flood. A new chapel, The Beautiful Chapel of Our Most Merciful Savior was built in its place, thanks to a gift from a supporter in Massachusetts.

It is the dedication of this missionary, Samuel Hinman, that led to the strong presence of the Episcopal Church among the Sioux. He showed love and concern for their lives and gave up much to minister among them.

As Paul Mazakute, whose Indian name is Iron Shooter, said today, "My ministry will be with the Dakotas—at Yankton Agency, and at White Swan, Choteau Creek, Ponca, and Santee, and on the Bazille."

**The Sioux later came to be known as the Lakota/Dakota people. Information contained in this article came from Jamestown Commitment: The Episcopal Church and the American Indian, by Owanah Anderson, pp. 54-55; Forward Movement Publications, 1988.*

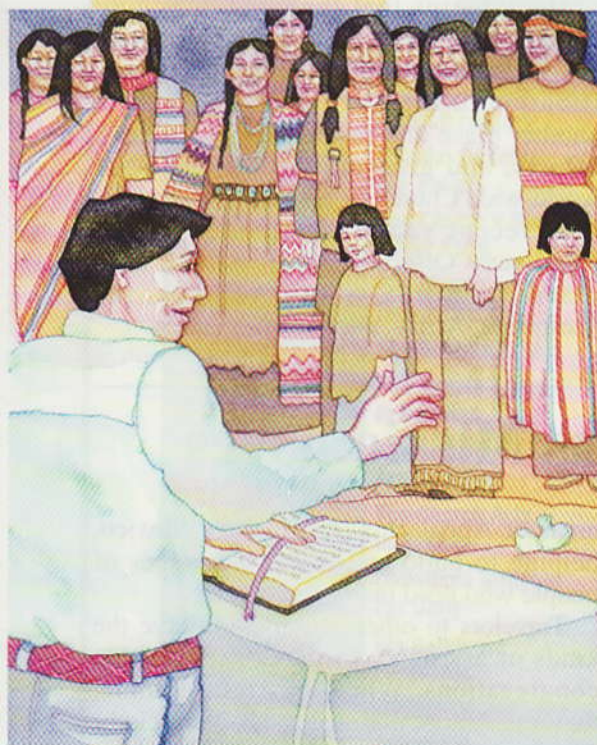

Cross Year—Intermediate,
Episcopal Children's
Curriculum
Copyright ©1995
Virginia Theological
Seminary and Morehouse
Publishing

Annual Offering Involves Children

From the Office of Children's Ministries at the Episcopal Church Center, New York, comes this description of an important annual emphasis among the congregations and missions:

"The Church School Missionary Offering (CSMO) is a program of the Episcopal Church that gives children and adults together the chance to learn about mission and ministry of the Church in another part of the world.

"Each year The Church School Missionary Offering publishes an issue of *TREASURE Magazine*, a leader's guide, and a study guide for adults, focusing on a different region or province of the world-wide Anglican Communion."

(Anglican Communion is the general name given to the many churches in the world that are related to—or were originally a part of—the Church of England. Although our Church in the United States is called "Episcopal," we are a part of this great Communion.)

Through the Church School Missionary Offering and *TREASURE Magazine*, "children get to know other Anglicans their own age growing up in another part of the world. They learn about the children's culture and traditions, their lives as Christians, and their problems and hopes.

"They are challenged to think about how the Church proclaims the Gospel and works for justice, and how they, too, are called by



CSMO

Church School Missionary Offering

the Holy Spirit to live with faith and hope and to serve with love in the world," writes the Rev. Howard K. Williams, in *Notes to Parents and Guardians*.

He explains that the Church School Missionary money offering allows young people an opportunity "to make a real contribution to the work of the Church in another place and to feel that their ideas, efforts, and gifts are important to the world-wide Church."

In recent years, the Church School Missionary Offering has focused on such places as Korea, South America, the Caribbean, Africa, and the Philippines.

"The Church School Missionary Offering (CSMO) is a program of the Episcopal Church that gives children and adults together the chance to learn about mission and ministry of the Church in another part of the world"

Many Persons Serve as Missionaries

Today, missionaries continue to assist in the Church's effort to do God's work throughout the world. Many ordained and lay people offer their gifts to people of other cultures and to their neighbors in North America.

Some are teachers who spend a year or more in other countries working in schools. While they may teach English, mathematics, and other subjects, they also offer instruction about Jesus and the Bible.

Some young people are short-term missionaries, spending their summers on Native American reservations, in rural

areas of Appalachia, and in New Mexico, helping to build and repair the homes of people who need them.

Travelers to other countries observe the kinds of assistance required by Christian congregations. When they return home, they raise money, collect books and clothing, or see that the needs of their neighbors in other places are met.

Being a missionary begins with learning about another country and the people who live there. It also means knowing about God and God's will for one's own life.

Sunday Schools Were Missionary Effort

One of the most successful missionary movements ever undertaken in this country was the Sunday School. Begun in England, it was brought to the newly-created United States of America by Bishop William White, one of the first bishops of the Episcopal Church.

John and Charles Wesley, among the first missionaries to the colony of Georgia, taught Sunday School there to poor children, both black and white.

The Sunday School followed the frontier settlers into the territories west of the

Mississippi River. Each new community quickly established a church and a Sunday School, equipped with Bibles and books to insure that the word of God would be present in every distant place.

The popularity of Sunday Schools increased rapidly, with hundreds of thousands of people volunteering their time to teach children and adults about God.

Still today, many teachers spend a major part of their Sunday mornings helping young people and others to learn the stories of the Bible and the history of the Church.

Answers:
 John Wesley
 Charles Wesley
 William White
 Korea
 Caribbean
 Africa
 North America
 South America
 Philippines
 China
 India
 Japan

MEMORY CHALLENGE

File Edit Window Help

Open

Unit IV

- Church History
- Creeds: Defining Our Beliefs
- The Church's Worship Takes Form
- The Church's Reformation
- The Bible Is for All
- The Church Came to America
- Missionaries Are Sent Out**
- The Church Acts in Society
- Christians Struggle For Unity
- We Celebrate Pentecost

Timeline (centuries)

4th 6th 14th 15th 16th 17th 18th 19th 20th

18th-19th Centuries

18th-19th Centuries-Key People and Events

- ✓ John and Charles Wesley, George Whitefield
- ✓ First American Episcopal Missionaries

Into the World

Directions: Unscramble the words to discover some people and places connected with missionary work in the Church.

HNSEYLOWEJ _____
 SSCHEWYARLEE _____
 IWAEMIHWTLLI _____
 ROKEA _____
 BARCINEAB _____
 RIFACA _____
 MANRORETHCIA _____
 MOUTHSRAAECI _____
 SIPPINEHILP _____
 NIAHC _____
 DINAI _____
 PNAJA _____



Unit IV: LEARNING SCRIPTURE

Verses for the Unit:

Session 1: *John 16:28; Philippians 2:11*
 Session 2: *Romans 12:2; Romans 14:8*
 Session 3: *Psalms 118:23; John 8:32; Romans 5:8*
 Session 4: *Luke 24:32; II Timothy 3:15*
 Session 5: *Matthew 5:16; John 17:18*
Session 6: *Luke 9:6; Romans 15:21*
 Session 7: *Matthew 25:35; Galatians 3:28*
 Session 8: *Romans 12:9; Ephesians 4:2*
 Session 9: *Acts 1:5; I Corinthians 12:4-6*



LEARNING SCRIPTURE

Session 6

“They departed and went through the villages, bringing the good news and curing diseases everywhere.”—*Luke 9:6* (NRSV)

“... [B]ut as it is written, ‘Those who have never been told of him shall see, and those who have never heard of him shall understand.’”

—*Romans 15:21* (NRSV)

ECC



**UNIT IV
ISSUE 7**

**The Church
Acts in Society**

Church Times

Young People in the Nation's Churches Offer Their Help in Local Relief Efforts

Many young people have been a part of relief efforts in communities recently hit by floods and other natural disasters. We interviewed several in different locations to find out why they have given time, energy, and money to help others.

"Our youth group has been studying the Bible. We believe that we should act on what Jesus taught us—to love our neighbors as ourselves and to help those in need."

Money for Earthquake Victims

The students in a nearby Sunday School class mowed lawns, did baby-sitting, ran errands, and washed cars to raise money for the victims of an earthquake in Japan.

Their teacher told us, "We have been studying the parable of the Good Samaritan. The boys and girls saw this as a way of being like a helping Samaritan to the people in Japan who have suffered great loss.

"It was their idea to raise money themselves instead of asking their parents or the church. They made a list of things they could do. Then they made posters and put them up around the church, their schools, and their neighborhoods. In a few weeks they had earned a substantial sum.

"The students even went to the bank and bought a money order. They sent it to a church in Japan that was collecting money to help the earthquake survivors."

We have heard numerous other stories about what youth have been doing as representatives of the church in the world. Many are involved in ministries to the homeless, volunteering in hospitals, and collecting funds for missions in other parts of the world. They are doing what they can to live out the message of the Gospel.

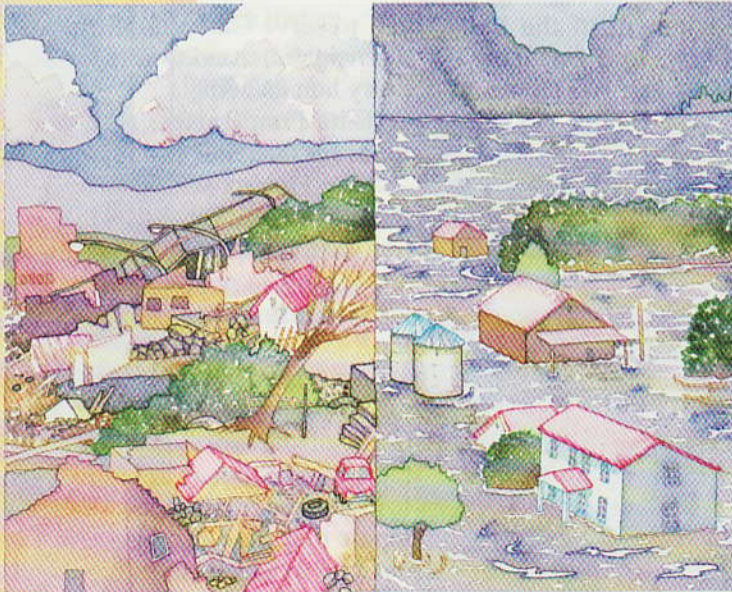

Cross Year—Intermediate,
Episcopal Children's
Curriculum
Copyright ©1995
Virginia Theological
Seminary and Morehouse
Publishing

In the Midwest, people along the river valleys were facing threats of disaster as the waters rose rapidly above flood stage.

Phoebe and Thomas spent endless hours with their friends, filling sand bags and carrying them to the river's edge.

When asked why, they replied, "When our youth group at church heard what would happen if the river valley floods, we got together and decided to come down here to help.

Church Bodies Have Long Been Active In Varied Ministries of Social Action

In the South, before the Civil War, groups of Christians risked their lives either by teaching slaves to read or by helping them escape to freedom.

In the late 1700s, Sunday Schools undertook to teach poor people to read and write. Often in opposition to government leaders, church members helped the poor in cities and in rural areas to learn about the Gospel by teaching them to read the Bible.

In the South, before the Civil War, groups of Christians risked their lives either by teaching slaves to read or by helping them escape to freedom.

In the 1960s, many churches and their leaders supported the work of Dr. Martin Luther King, Jr., in his efforts to bring about equality for all people. In doing so,

Christians were living out the teachings of the apostle Paul who said that in Christ "there is no longer slave or free."

Around the globe, Archbishop Desmond Tutu, a bishop of the Anglican Church in South Africa, worked hard to overcome racism in his country. Countless Christians around the world prayed and supported the effort to break down racial barriers there.

It takes many years to overcome prejudice and hatred. We recognize this when we repeat again and again the promise of the Baptismal Covenant, to "strive for justice and peace among all people, and respect the dignity of every human being."

How Does the Church Respond to Needs Of Suffering People Around the World?

The mission statement of the Presiding Bishop's Fund for World Relief reminds us that it is "a major response by the Episcopal Church to God's

call to serve Christ in all persons, to love our neighbors, and to respect the dignity of every human being.

"The Fund raises, receives, and uses funds for the relief of human suffering.

"The Fund provides emergency relief in times of disaster; it assists in the rehabilitation of lives, property, and organizations; and it joins in partnerships with those who identify and address root causes of suffering."

In a typical year, between three and four million dollars are distributed to every continent of the world and many dioceses in the United States. These funds are used to feed the hungry, provide medical care, and repair damaged property. Money is also used to establish organizations for job training, education, and transportation.

The Fund also helps other agencies, such as Bread for the World, Heifer Project International, World YMCA, and World YWCA.

Individuals or churches can send money to The Presiding Bishop's Fund for World Relief at the Episcopal Church Center in New York.

Presiding Bishop's Fund for World Relief

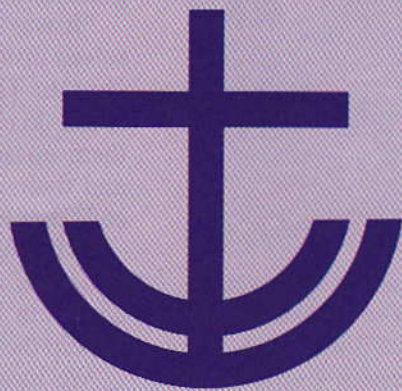

I Have a Dream

"I have a dream that one day on the red hills of Georgia the sons of former slaves and the sons of former slave owners will be able to sit down together at the table of brotherhood. . . . I have a dream my four little children will one day live in a nation where they will not be judged by the color of their skin but by the content of their character . . . and when we allow freedom to ring . . . we will be able to speed up that day when all of God's children—black and white, Jews and Gentiles, Catholics and Protestants—will be able to join hands and sing in the words of the old Negro spiritual, 'Free at last, free at last, thank God almighty, we are free at last.'"

—Dr. Martin Luther King, Jr., August 28, 1963, at the March on Washington, D.C. (excerpt)

How does Dr. King's dream compare with the dream of the prophet recorded in *Isaiah, chapter 11*? Or with the apostle Paul's words in Galatians 3:28-29?

Answer:

"Will you seek and serve Christ in all persons, loving your neighbor as yourself?"

Will you strive for justice and peace among all people, and respect the dignity of every human being?
I will, with God's help."

—*The Book of Common Prayer*, p.305

MEMORY CHALLENGE

File Edit Window Help

Open

Unit IV

Church History

Creeds: Defining Our Beliefs

The Church's Worship Takes Form

The Church's Reformation

The Bible Is for All

The Church Came to America

Missionaries Are Sent Out

The Church Acts in Society

Christians Struggle For Unity

We Celebrate Pentecost

Timeline (centuries)

4th 6th 14th 15th 16th 17th 18th 19th 20th

1950s—1960s

1950s—1960s-Key People and Events

✓ Martin Luther King, Jr., Civil Rights movement



SECRET CODE

Directions: Using the code below, discover the secret message.
Write the letters over the numbers.

“23 9 12 12 25 15 21 19 5 5 11 1 14 4
 19 5 18 22 5 3 8 18 9 19 20 9 14 1 12 12
 16 5 18 19 15 14 19, 12 15 22 9
 14 7 25 15 21 18 14 5 9 7 8 2 15 18
 1 19 25 15 21 18 19 5 12 6?
 23 9 12 12 25 15 21 19 20 18 9 22 5 6 15 18
 10 21 19 20 9 3 5 1 14 4 16 5 1 3 5
 1 13 15 14 7 1 12 12 16 5 15 16 12 5,
 1 14 4 18 5 19 16 5 3 20 20 8 5
 4 9 7 14 9 20 25 15 6 5 22 5 18 25
 8 21 13 1 14 2 5 9 14 7?
 9 23 9 12 12, 23 9 20 8 7 15 4 19 8 5 12 16.”

—The Book of Common Prayer, p.305

The Church and Human Justice

Code:

a = 1	n = 14
b = 2	o = 15
c = 3	p = 16
d = 4	q = 17
e = 5	r = 18
f = 6	s = 19
g = 7	t = 20
h = 8	u = 21
i = 9	v = 22
j = 10	w = 23
k = 11	x = 24
l = 12	y = 25
m = 13	z = 26

Unit IV: LEARNING SCRIPTURE

Verses for the Unit:

Session 1: *John 16:28; Philippians 2:11*

Session 2: *Romans 12:2; Romans 14:8*

Session 3: *Psalms 118:23; John 8:32;*
Romans 5:8

Session 4: *Luke 24:32; II Timothy 3:15*

Session 5: *Matthew 5:16; John 17:18*

Session 6: *Luke 9:6; Romans 15:21*

Session 7: *Matthew 25:35;*
Galatians 3:28

Session 8: *Romans 12:9; Ephesians 4:2*

Session 9: *Acts 1:5; I Corinthians 12:4-6*



LEARNING SCRIPTURE

Session 7

“... [F]or I was hungry and you gave me food, I was thirsty and you gave me something to drink, I was a stranger and you welcomed me. ...”
—*Matthew 25:35* (NRSV)

“There is no longer Jew or Greek, there is no longer slave or free, there is no longer male and female; for all of you are one in Christ Jesus.”
—*Galatians 3:28* (NRSV)

ECC



**UNIT IV
ISSUE 8**

**Christians
Struggle for
Unity**

Church Times



Young People Plan Ecumenical Event To Encourage Discussions of Faith

Several churches in the area are sponsoring an ecumenical gathering for young people. The theme is "Getting It Together." All local churches whose denominations are members of the National Council of Churches have been invited to take part.

The organizers explained their goals:

"A Sunday School class at St. Stephen's Episcopal Church came up with the idea first. They had been studying the history of the ecumenical movement. As a project, they decided to see if they could get support for a local ecumenical gathering.

"The students approached local ministers and asked for support. The clergy were excited by their initiative. The plans for the event have taken off from there."

We interviewed students to find out what they hoped to gain from the upcoming event. One leader said, "We want to help others learn what Christians have in common—what caused the churches separation into denominations. If young persons can understand one another's beliefs and work together, maybe adults will, too."

Movement Described

The students have sent out a leaflet that shares the following background information:

"Ecumenical is an ancient Greek word that means *whole* or *universal*. In the twentieth century, the 'ecumenical movement' began with the Volunteer Student Movement. These were young people led by a distinguished Christian leader, John R. Mott. Their initiative led to a larger meeting in Edinburgh, Scotland, in 1910.

"From that gathering came these additional meetings to promote study and cooperation: International Missionary Council (1921); Life and Work (1925); and Faith and Order (1927).

These sessions brought together Protestant church leaders from all over the world, to talk about the things Christians have in common and the things that keep us apart.

"World War II kept people from continuing the conversations, but leaders kept on planning. In 1948, the first meeting of the World Council of Churches was held in Amsterdam. From 147 churches came 351 delegates. They declared their intention to stay together.

"There have been lots of meetings since, and several denominations are working toward greater understanding and acceptance.

"Our class thinks that world and national leaders can only do so much. We want to see what we can do right here, talking with one another."

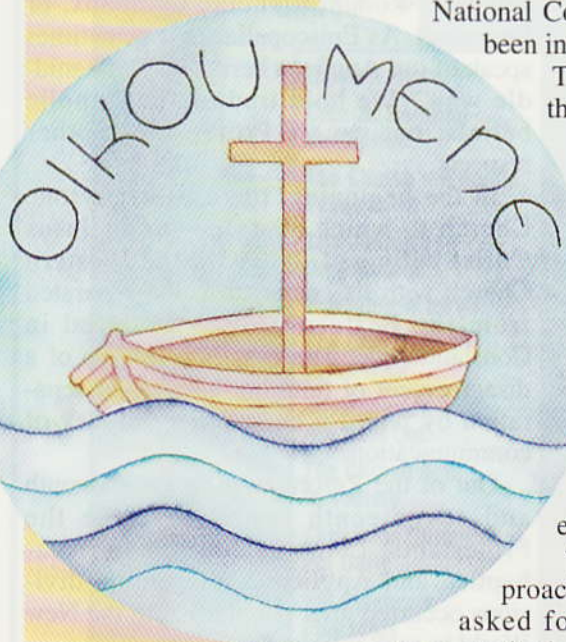

Cross Year—Intermediate,
Episcopal Children's
Curriculum
Copyright ©1995
Virginia Theological
Seminary and Morehouse
Publishing

National Council Promotes Cooperation

The purpose of the National Council is to find common ground for belief and action.

The National Council of Churches of Jesus Christ in the United States of America was formed in 1950. It combined several organizations that had been working to promote Christian unity.

While its members are mostly from Protestant and Orthodox denominations, representatives from the Roman Catholic Church have been invited to Council meetings and frequently attend as observers. (Roman Catholic participation has been wider since Vatican Council II in the early 1960s.)

The purpose of the National Council is to find common ground for belief and action.

The differences in the teachings of the denominations—known as doctrines—are the focus of many discussions and study groups. These teachings have developed over the centuries as individual denominations have defined who they are by their practices and rituals.

Among its practical achievements has been the Council's cooperative programs for the relief of world hunger.

The National Council holds the copyright of the Revised Standard and New Revised Standard Versions of the Bible. Scholars of the member churches served on the committees that produced these important translations.

Major Christian Bodies Have Splintered

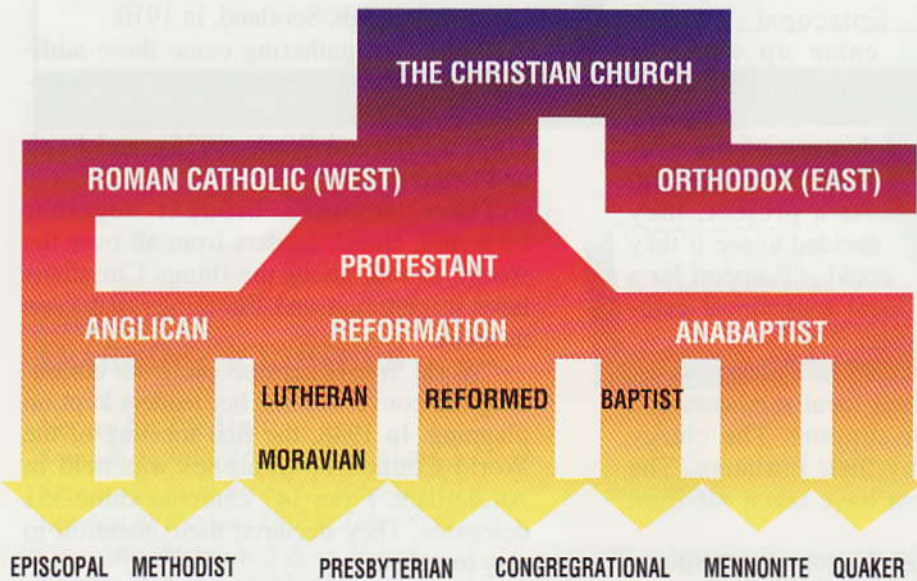

While there are many thousands of religions in the world, most Christians will identify themselves as Roman Catholic, Orthodox, or Protestant. As Episcopalians we sometimes speak of our Anglican heritage as “the middle way.” We hold traditional Catholic beliefs, but we are Protestant in other respects.

In the beginning, there was only one Church to which all followers of Jesus Christ belonged. In 1054, the Western Church with its center in Rome separated from the Eastern Church centered in Constantinople. This was not because of a disagreement of faith but because of separation by political boundaries and lack of communication.

Out of the Reformation in the sixteenth and seventeenth centuries came the Protestants: Lutheran, Reformed, Anabaptist, and Anglican. Many more divisions occurred after people fled to the New World to seek religious freedom.

Major denominations that flourished in the American colonies were Methodist, Presbyterian, Congregationalist, Baptist, and Quaker (Society of Friends). After the American Revolution, the Episcopal Church was formed to continue the Anglican tradition in this country.

Why So Many Different Denominations?

Why have so many different churches developed when we all believe in one God and in Jesus Christ?

We all believe in the same God, but we claim different beliefs and practices. For example, infants are baptized in some churches, including the Episcopal Church. In other churches, baptism is reserved for persons who are old enough to make their own confessions of faith.

The ordination of ministers is a major area of disagreement among Christian churches. Episcopal priests are ordained by a bishop. We believe that this sacramental

rite continues what is called "Apostolic succession."

Ordinations by bishops began with the Apostles in the early Church and has continued in an unbroken line of succession throughout the centuries. (When Samuel Seabury and William White traveled to Scotland and England to be ordained bishops for the Episcopal Church, they did so to preserve the Apostolic succession.)

Other churches follow different procedures to ordain ministers. Some ministers (priests) are permitted to marry, others cannot. Some denominations ordain women, others do not.

Answers:

- Baptist
- Congregationalist
- Roman Catholic
- Presbyterian
- Episcopal
- Lutheran
- Friends
- Methodist
- Mennonite

MEMORY CHALLENGE

File Edit Window Help

Open

Unit IV

- Church History
- Creeds: Defining Our Beliefs
- The Church's Worship Takes Form
- The Church's Reformation
- The Bible Is for All
- The Church Came to America
- Missionaries Are Sent Out
- The Church Acts in Society
- Christians Struggle For Unity
- We Celebrate Pentecost

Timeline (centuries)

4th 6th 14th 15th 16th 17th 18th 19th 20th

1948

1948-Key People and Events

✓ World Council of Churches

SCRAMBLE

Christian Churches

Directions: Unscramble the words to find the names of different Christian churches.

PATBIST



GORENCTAGNOLIASTI

CARMANTOHOCIL

BRIANTERSPYE

PECLAPSIO

HUTRELNA

DFSINRE

DOTTEMHIS

EOMNINETN

Unit IV: LEARNING SCRIPTURE

Verses for the Unit:

Session 1: *John 16:28; Philippians 2:11*

Session 2: *Romans 12:2; Romans 14:8*

Session 3: *Psalms 118:23; John 8:32;*

Romans 5:8

Session 4: *Luke 24:32; II Timothy 3:15*

Session 5: *Matthew 5:16; John 17:18*

Session 6: *Luke 9:6; Romans 15:21*

Session 7: *Matthew 25:35; Galatians 3:28*

Session 8: *Romans 12:9; Ephesians 4:2*

Session 9: *Acts 1:5; I Corinthians 12:4-6*



LEARNING SCRIPTURE

Session 8

“Let love be genuine; hate what is evil, hold fast to what is good; . . .”
—*Romans 12:9* (NRSV)

“. . . [W]ith all humility and gentleness, with patience, bearing with one another in love, . . .” —*Ephesians 4:2* (NRSV)

ECC



**UNIT IV
ISSUE 9**

**We Celebrate
Pentecost**

Church Times



Apostle Paul Restores Life of Young Man Who Fell to the Ground from Window

TROAS, first century CE—Eutychus, a young man of Troas, fell out of a window during a late night gathering here as the Apostle Paul was holding a long discussion with a local group who call themselves Christians. The youth was picked up dead, but Paul brought him back to life.

The apostle had been in Troas for seven days, having arrived here from Philippi.

It was the first day of the week, and the Christians met to break bread, a ritual part of

their worship. After the sacred meal, Paul was speaking with the group about many things. He talked on until midnight, and many lamps were burning in the room on the upstairs floor of the house where they were meeting.

Apparently, Eutychus was sitting in an open window, probably for fresh air. While Paul spoke, the boy grew tired,

closed his eyes in sleep, and toppled out of the window to the ground below.

The whole assembly, including Paul, raced down the stairs. They were sure such a fall would mean death. Some of the women began to cry.

When the apostle reached the youth, he took him in his arms and said to those who were gathered around, "Do not be alarmed, for his life is in him." Eutychus was carried home alive and well, but weary.

Day of Pentecost

Paul is a Jew from Jerusalem. He has been traveling about the countryside, spreading good news of Jesus Christ. He tells the life story of this man he believes to be the Son of God.

He also carries news of other followers of Christ in Jerusalem who were empowered with the Holy Spirit a few years ago. The occasion was the Day of Pentecost—the annual Jewish harvest celebration. Large crowds had traveled to Jerusalem to worship in the temple and offer sacrifices.

At the time of the festival, the followers of Jesus were gathered at a house when the Holy Spirit came upon them like a violent wind and fire. This experience led them to speak boldly and joyfully about their new faith.

Sometime later, Paul himself had a dramatic encounter with the Holy Spirit. He has changed from being a persecutor of Christians to being one of their most devout leaders.

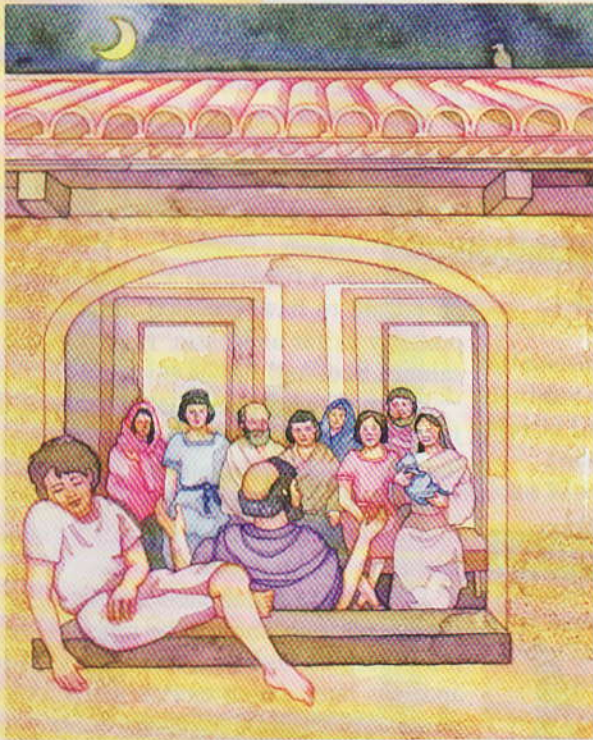

Cross Year—Intermediate,
Episcopal Children's
Curriculum
Copyright ©1995
Virginia Theological
Seminary and Morehouse
Publishing

Many signs and wonders were done by the apostles.

The Holy Spirit Led Christ's Followers To Share Good News and Heal the Sick

After their experience at Pentecost, when the apostles received the gift of the Holy Spirit, Peter preached a sermon to a huge gathering. Three thousand people were baptized that day.

Each day the Lord added to the number who sought baptism. They prayed in the temple and praised God with glad and generous hearts.

As Peter and John were going to the temple one day, they saw a beggar sitting by the Beautiful Gate. Peter said to the beggar, "I have no silver or gold, but what I

have I give you; in the name of Jesus Christ of Nazareth, stand up and walk."

The beggar rose to his feet with Peter's help, and his legs became strong. He jumped up and entered the temple, walking and leaping and praising God.

Many signs and wonders were done by the apostles. People were amazed, and they would bring their sick out into the streets so that Peter's shadow might pass over them. Such a strong faith led to many believers among the men and women of Jerusalem.

PETER



PHILIP



JOHN



JAMES, The Greater



BARTHOLOMEW



From the New Testament we can piece together a small amount of information about the apostles. Other details have come to us from legends outside the Bible.

Peter, the Rock, left Jerusalem and visited Paul in Greece. Later he went to Rome and was crucified, head down, saying, "I am not worthy to be crucified as my Lord was."

Andrew, a fisherman and Peter's brother, is said to have traveled into the north, possibly as far as Russia. He is the patron saint of Scotland.

Thomas, who wanted to be shown that Jesus had indeed risen, took the Gospel to India.

Bartholomew may also have gone to India. He returned by way of Armenia, where he was martyred.

John, son of Zebedee and brother of James, became one of the inner circle of the disciples. John went to Asia Minor and was later exiled to Patmos, where he wrote the Book of Revelation, and died alone of old age.

James the Greater, the brother of John, was also a member of the inner circle. He may have gone to Spain. So many miracles are attributed to him that he has become the patron saint of Spain.

James the Less is sometimes referred to

Continued on page 3

APOSTLES, *Continued from page 2*

as the son of Alphaeus. He died in Jerusalem after being hurled from the roof of the temple.

Philip is mentioned in the Bible as the one who met with an Ethiopian and baptized him in the waters nearby. Tradition has Philip in Hierapolis where he slew a dragon.

Matthew, the tax collector, wrote his Gospel in Judea, and then went to preach in Ethiopia where he died.

Simon and Jude went to Persia. An interesting legend says that Simon may have been one of the shepherds who saw the angels on the night Jesus was born.



SIMON



MATTHEW

Answer: See Acts 2:1-4 (NRSV).

MEMORY CHALLENGE

File Edit Window Help

Open

Unit IV

Church History

Creeds: Defining Our Beliefs

The Church's Worship Takes Form

The Church's Reformation

The Bible Is for All

The Church Came to America

Missionaries Are Sent Out

The Church Acts in Society

Christians Struggle For Unity

We Celebrate Pentecost

Timeline (centuries)

4th 6th 14th 15th 16th 17th 18th 19th 20th



4th-20th Centuries

4th-20th Centuries Key People and Events

1. Athanasius, Nicene Creed, Ambrose—4th Century
2. Benedict of Nursia, Monastic Movement —6th Century
3. Martin Luther, John Calvin, Protestant Reformation
Thomas Cranmer, first Prayer Book—16th Century
4. John Wycliffe, William Tyndale, King James Bible
—14th through 17th Centuries
5. Virginia and Massachusetts Bay Colonies —17th Century
6. John and Charles Wesley, George Whitefield—18th Century
First American Episcopal Missionaries—19th Century
7. Martin Luther King, Jr. and Civil Rights Movement
—20th Century
8. World Council of Churches—20th Century



When the Church Began

Directions: Fill in the **BLANKS** to complete this passage from Scripture.

When the day of _____ had come, they were all _____ in one place. And suddenly from _____ there came a _____ like the rush of a _____, and it filled the entire _____ where they were sitting. Divided _____, as of _____, appeared among them, and a _____ rested on each of them. All of them were _____ with the _____ and began to speak in other _____, as the _____ gave them ability.



Unit IV: LEARNING SCRIPTURE

Verses for the Unit:

Session 1: *John 16:28; Philippians 2:11*

Session 2: *Romans 12:2; Romans 14:8*

Session 3: *Psalms 118:23; John 8:32;*
Romans 5:8

Session 4: *Luke 24:32; II Timothy 3:15*

Session 5: *Matthew 5:16; John 17:18*

Session 6: *Luke 9:6; Romans 15:21*

Session 7: *Matthew 25:35; Galatians 3:28*

Session 8: *Romans 12:9; Ephesians 4:2*

Session 9: *Acts 1:5; I Corinthians 12:4-6*

LEARNING SCRIPTURE

Session 9

“... [F]or John baptized with water, but you will be baptized with the Holy Spirit not many days from now.”—*Acts 1:5* (NRSV)

“Now there are varieties of gifts, but the same Spirit; and there are varieties of services, but the same Lord; and there are varieties of activities, but it is the same God who activates all of them in everyone.”

—*I Corinthians 12:4-6* (NRSV)